

Features

ADH 110 centrifugal pump with mechanical seal are made of plastic materials (Polypropylene and PVDF) and are suitable for high corrosive liquids. They are operated by a direct-drive motor (max 3000 rpm). Their special open-impeller design allows pumping even with very dirty liquids having apparent viscosity up to 500 cps (at 20°C) and small suspended solids.

There are two versions available with different internal mechanical seal depending on use, A (lip seal) and B (bellows seal.)



Technical data

Construction Materials	PP - PVDF
Max. Capacity	20 m ³ /h
Max Head	15 m
Max Temperature	PP 60°C - PCDF 90°C
Max Viscosity	500 cPs
Max.diameter of passing solids	2 mm
Intake / delivery connections	2 " M x 1 1/2" M - DN50 X DN40 on request
Motor	1.5 HP 380V3/50Hz / 2800 rpm
Pump weight with motor	PP 16 Kg - PVDF 17Kg

Installation

ADH 110 horizontal centrifugal pump should be installed with the shaft positioned horizontally in a positive suction head arrangement. Suitable devices should be fitted to prevent dry running and the formation of a vortex and possible air suction. ADH 110 horizontal centrifugal pump should only operate whilst filled.

Running dry or with bubbles can cause damage to the mechanical seal.

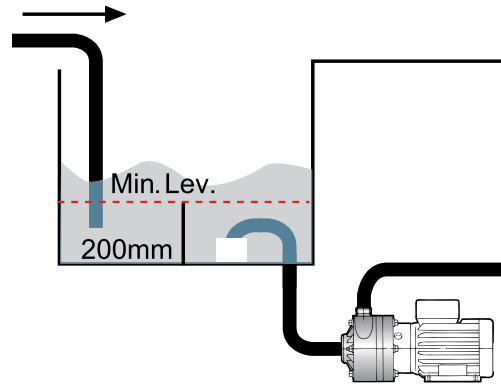

Description of the Pump

Resin-encased horizontal centrifugal pumps feature a solid pump casing and a lantern for connecting the electric motor and inspection of the mechanical seal. The open impeller is fitted to the pump shaft that is integral with the drive shaft of the electric motor. The shaft mechanical seal is housed at the rear of the impeller.

- 1 = electric motor
- 2 = inspection lantern
- 3 = mechanical seal
- 4 = impeller
- 5 = Delivery connection
- 6 = Intake connection

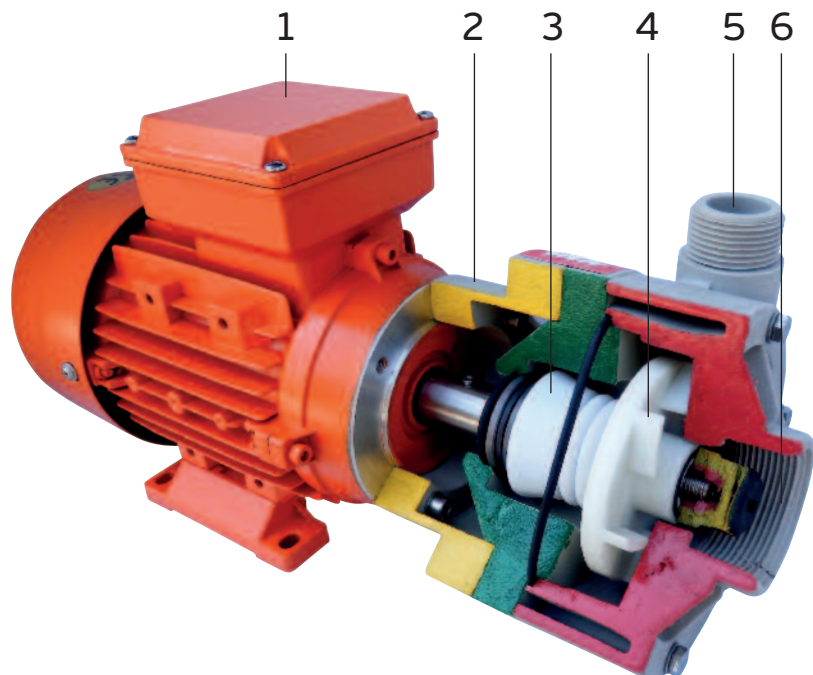

Performance curves 2900 Rpm

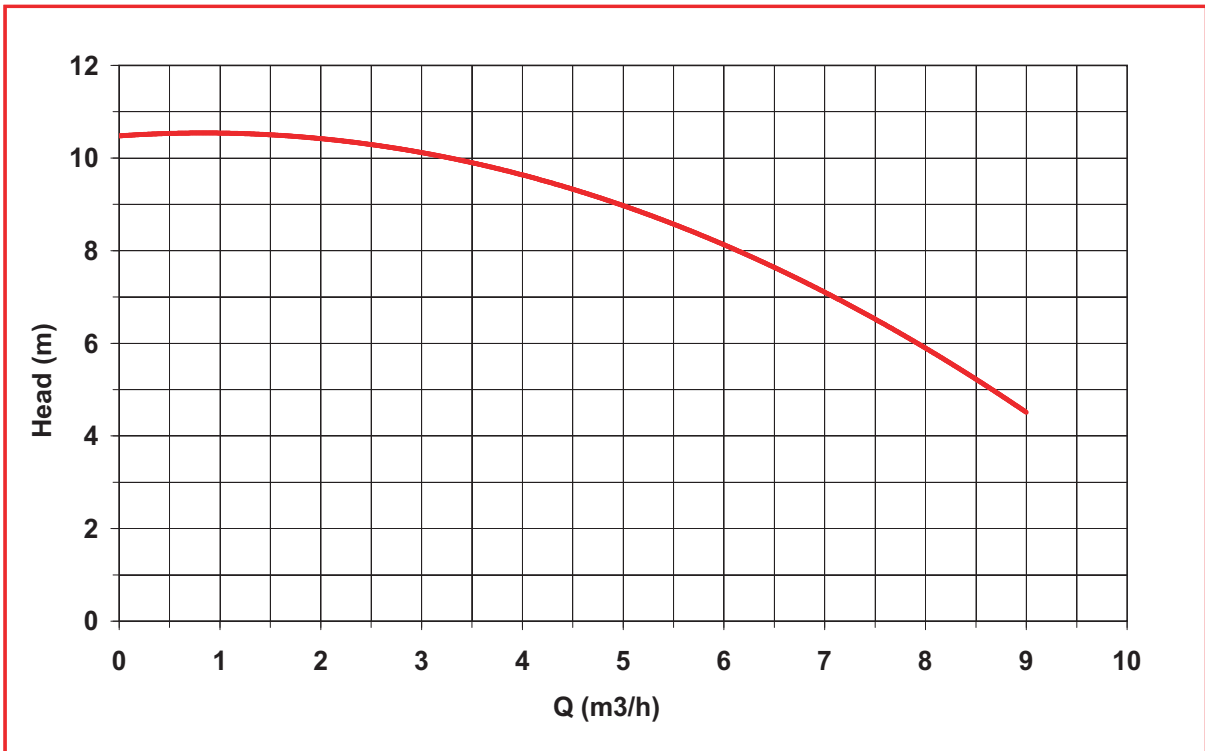

Dimensions

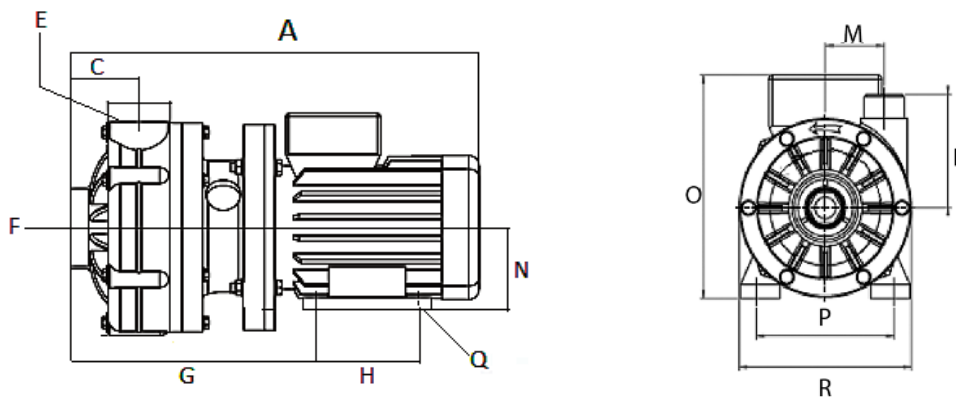

Pump Type	Motor Flange B3-B5	Kw	Rpm	Dimensions -mm-												
				A	C	E	F	G	H	L	M	N	O	P	R	Q
ADH 110	80	1.1	2800	406	75	1 1/2" M - DN 40	2" M - DN 50	247	100	130	40	80	191	125	203	4 X Φ 10

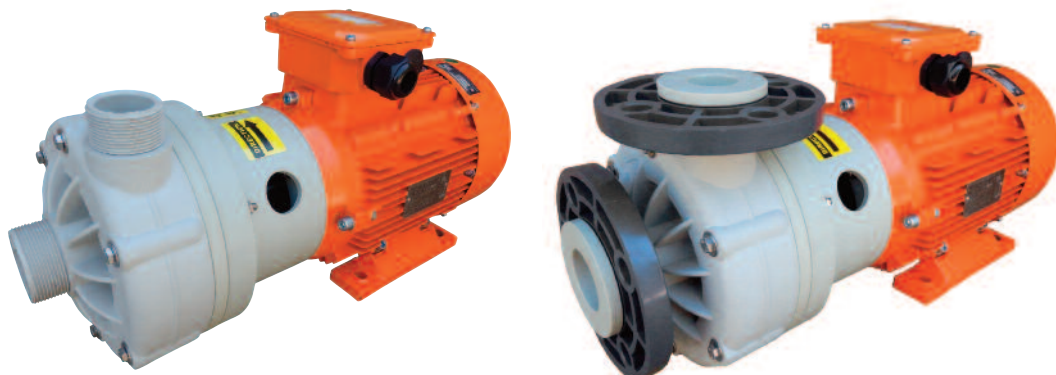

ALPHADYNAMIC PUMPS Co

England Sales office:

Rockleigh House, 37 Burton Road
Ashby de la Zouch, Leicestershire
LE65 2LF - United Kingdom (UK)
Registered in ENGLAND & WALES
Registration number 09706219 - VAT No.GB220393343
Tel +44 1213 680 324, +44 1213 680472
email:sales@alphadynamicpumps.co.uk
www.alphadynamicpumps.co.uk

Hellas Production Facilities Unit 1

3 Eleftherias Str Industrial Park of Kifisia
14564 - Kifisia - Hellas
VAT No. EL 999695309
Tel +30 210 4200 338, +30 210 4200 422
Fax +30 211 268 68 37
email: info@alphadynamic.eu
www.alphadynamic.eu

Hellas Production Facilities Unit 2

30 Seneka str Industrial Park of Kifisia
14564 - Kifisia - Greece
Tel +30 215 215 9152
email: sales@rubypump.com