

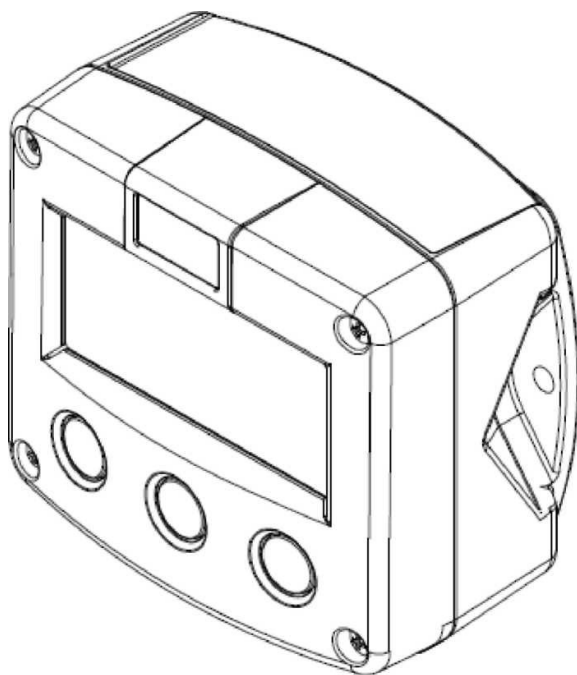

F130-P BATCH-CONTROLLER



INSTRUCTION MANUAL

Signal input flowmeter type P: pulse, Namur and coil.

Status inputs: start and stop.

Control output: two control outputs for two stage control, or one control output and pulse output ref. total.

CONTENTS MANUAL

Safety instructions.....	3
Safety rules and precautionary measures.....	3
About the operation manual.....	4
1. Introduction.....	5
1.1. System description of the F130-P.....	5
2. Operational.....	7
2.1. General.....	7
2.2. Control panel.....	7
2.3. Operator information and functions.....	8
3. Configuration.....	10
3.1. Introduction.....	10
3.2. Programming SETUP-level.....	10
3.2.1. General.....	10
3.2.2. Overview functions SETUP level.....	13
3.2.3. Explanation OF SETUP-functions.....	13
1 - Preset.....	13
2 - Overrun.....	14
3 - Alarm.....	14
4 - Display.....	15
5 - Power management.....	15
6 - Flowmeter.....	15
7 - Relay output.....	16
8 - Communication (optional).....	16
9 - Others.....	16
4. Installation.....	17
4.1. General directions.....	17
4.2. Installation / surrounding conditions.....	17
4.3. Dimensions- Enclosure.....	18
4.4. Installing the hardware.....	19
4.4.1. Introduction.....	19
4.4.2. Voltage selection sensor supply.....	20
4.4.3. Terminal connectors.....	21
5. Maintenance.....	27
5.1 Repair.....	27
Appendix : Problem solving.....	28

SAFETY INSTRUCTIONS



Any responsibility is lapsed if the instructions and procedures as described in this manual are not followed.



LIFE SUPPORT APPLICATIONS: The F130-P is not designed for use in life support appliances, devices, or systems where malfunction of the product can reasonably be expected to result in a personal injury. Customers using or selling these products for use in such applications do so at their own risk and agree to fully indemnify the manufacturer and supplier for any damages resulting from such improper use or sale.



Electro static discharge does inflict irreparable damage to electronics! Before installing or opening the unit, the installer has to discharge himself by touching a well-grounded object.



This unit must be installed in accordance with the EMC guidelines (Electro Magnetic Compatibility).



Do connect a proper grounding to the aluminum casing as indicated if the F130-P has been supplied with the 115-230VAC power-supply type PM. The green /yellow wire between the back-casing and removable terminal-block may never be removed.

SAFETY RULES AND PRECAUTIONARY MEASURES

- The manufacturer accepts no responsibility whatsoever if the following safety rules and precautions instructions and the procedures as described in this manual are not followed.
- Modifications of the F130-P implemented without preceding written consent from the manufacturer, will result in the immediate termination of product liability and warranty period.
- Installation, use, maintenance and servicing of this equipment must be carried out by authorized technicians.
- Check the mains voltage and information on the manufacturer's plate before installing the unit.
- Check all connections, settings and technical specifications of the various peripheral devices with the F130-P supplied.
- Open the casing only if all leads are free of potential.
- Never touch the electronic components (ESD sensitivity).
- Never expose the system to heavier conditions than allowed according to the casing classification (see manufacturer's plate and chapter 4.2.).
- If the operator detects errors or dangers, or disagrees with the safety precautions taken, then inform the owner or principal responsible.
- The local labor and safety laws and regulations must be adhered to.

ABOUT THE OPERATION MANUAL

This operation manual is divided into two main sections:

- The daily use of the unit is described in chapter 2 "Operation". These instructions are meant for users.
- The following chapters and appendices are exclusively meant for electricians/technicians. These provide a detailed description of all software settings and hardware installation guidance.

This operation manual describes the standard unit as well as most of the options available. For additional information, please contact your supplier.

A hazardous situation may occur if the F130-P is not used for the purpose it was designed for or is used incorrectly. Please carefully note the information in this operating manual indicated by the pictograms:



A "**warning**" indicates actions or procedures which, if not performed correctly, may lead to personal injury, a safety hazard or damage of the F130-P or connected instruments.



A "**caution**" indicates actions or procedures which, if not performed correctly, may lead to personal injury or incorrect functioning of the F130-P or connected instruments.



A "**note**" indicates actions or procedures which, if not performed correctly, may indirectly affect operation or may lead to an instrument response which is not planned.

1. INTRODUCTION

1.1 System description for F130

Functions and features

The batch controller model F130-P is a microprocessor driven instrument designed for batching and filling of small batch sizes up to large quantities as well as displaying total and accumulated total. This product has been designed with a focus on:

- ultra-low power consumption to allow long-life battery powered applications (type P B / PC);
- intrinsic safety for use in hazardous applications (type XI),
- several mounting possibilities with GRP or aluminum enclosures for industrial surroundings,
- ability to process all types of flowmeter signals,
- transmitting possibilities with analog / pulse and communication (option) outputs.

Flowmeter input

This manual describes the unit with a pulse type input from the flowmeter "-P version". One flowmeter with a passive or active pulse, Namur or sine wave (coil) signal output can be connected to the F130-P. To power the sensor, several options are available.

Standard outputs

- Two transistor or relay for two-stage control or one stage with pulse output, The configurable pulse output offers a scaled pulse mirroring a certain totalized quantity. Maximum frequency 60Hz ; the pulse length can be set from 7,8msec up to 2 seconds.

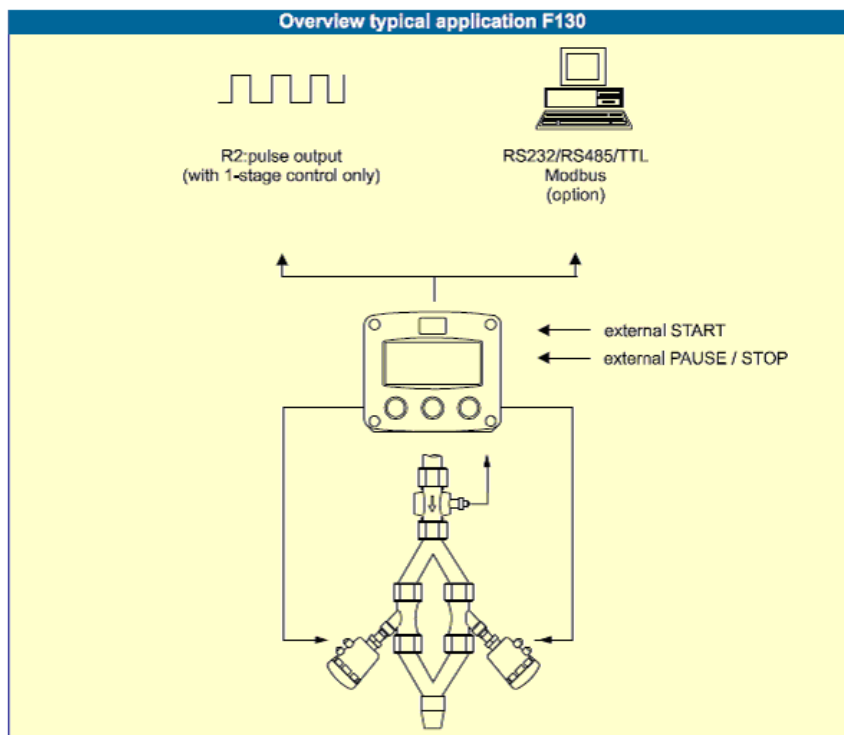

Configuration of the unit

The F130-P was designed to be implemented in many types of applications. For that reason, a SETUP-level is available to configure your F130-P according to your specific requirements. SETUP includes several important features, such as K-factors, measurement units, signal selection etc. All settings are stored in EEPROM memory and will not be lost in the event of power failure or a drained battery.

To extend the battery-life time, please make use of the power-management functions as described in chapter 3.2.3.

Display information

The unit has a large transfective LCD with all kinds of symbols and digits to display measuring units, status information and key-word messages.

A backup of the total and accumulated total in EEPROM memory is made every minute.

Options

The following options are available: full Modbus communication RS 232/485 (also battery powered), intrinsic safety, mechanical relay or active outputs, power- and sensor-supply options, LED backlight, panel-mount, wall-mount and weather-proof enclosures, flame proof enclosure.

2. OPERATIONAL

2.1. GENERAL



The F130-P may only be operated by personnel who are authorized and trained by the operator of the facility. All instructions in this manual are to be observed.

Take careful notice of the " Safety rules, instructions and precautionary measures " in the front of this manual.

This chapter describes the daily use of the F130-P. This instruction is meant for users / operators.

2.2. CONTROL PANEL

The following keys are available:



Fig. 2: Control Panel.

Functions of the keys



This key is used to program and save new values or settings.
It is also used to gain access to SETUP-level; please read chapter 3.



This key is used to START the batch process.
The arrow-key \blacktriangle is used to increase a value after PROG has been pressed or to configure the unit; please read chapter 3.



Press STOP to "PAUSE" the batch process. When this key is pressed twice, the process is completely finished and can't be continued.
STOP is also used to select Total and accumulated total.
After PROG has been pressed, the arrow-key \blacktriangleright is used to select a value

2.3 OPERATOR INFORMATION AND FUNCTIONS

In general, the F130-P will always function at Operator level. The information displayed is dependant upon the SETUP-settings. All pulses generated by the connected flowmeter are measured by the F130-P in the background, whichever screen refresh rate setting is chosen. After pressing a key, the display will be updated very quickly during a 30 second period, after which it will slow-down again.

■ To enter a batch quantity

To change the PRESET-value, following procedure must be followed:

- 1) press PROG the word "PROGRAM" will be flashing,
- 2) use ► to select the digits and ^ to increase that value,
- 3) set the new PRESET-value by pressing ENTER.



Fig. 3: Example display information during programming preset value.

When data is altered but ENTER has not been pressed yet, then the alteration can still be cancelled by waiting for 20 seconds or by pressing ENTER during three seconds: the former value will be reinstated. The PRESET-value can be used time after time till a new value is programmed.



Please note that alterations will only be set after ENTER has been pressed!

■ Batch maximum

When you program a new value which is not valid - the batch size is too large - the decrease-sign" will be displayed while you are programming; the new value will not be accepted!

■ Starting up the batch process

The batch process can only be started up when "READY" is displayed. The batch process is started-up by pressing the START-key. Depending on the SETUP-settings, one or two relays will be switched. The arrows at the display indicate if the ACTUAL-value is I was counting up or down.

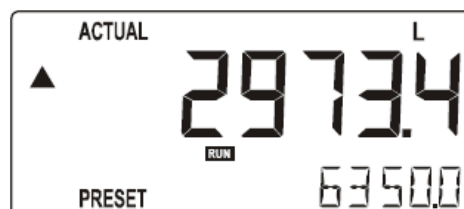

Fig. 4: Example display information during the process.

- **Interrupting and ending the batch process**

When STOP is pressed once, the batch process will be temporarily interrupted; the actual values are not lost. At the display, the word "PAUSE" will be flashing. From this stage, the batch process can be resumed with the START-key.

The process can be ended entirely at all times by pressing STOP twice in which case the actual values are "lost" and the system returns to steady state: the batch can not be resumed.

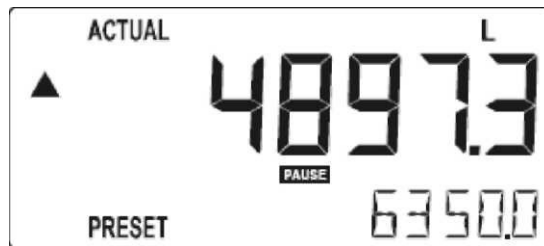

Fig. 5: Example display information when interrupted.

After batching, following functions are available:

- **Clear total**

The value for total can be re-initialized. To do so, select Total and press PROG followed by STOP - STOP. After pressing STOP once, the flashing text "PUSH STOP" is displayed. To avoid re-initialization at this stage, press another key than STOP or wait for 20 seconds. Re-initialization of total DOES NOT influence the accumulated total.

- **Display accumulated total**

When the STOP-key is pressed, total and accumulated total are displayed. The accumulated total cannot be re-initialized. The value will count up to 99,999,999,999. The unit and number of decimals are displayed according to the configuration settings for preset.

- **No flow alarm**

The F130-P offers a no-flow monitoring feature: if the flowmeter fails to generate a signal during a certain period of time, the unit will shut-off the control output(s) and bring the batch controller in alarm status. After clearing the alarm, the batch can be continued or denied.

- **Alarm 01-03**

When "ALARM" is displayed, press the SELECT key to display the reason of the alarm: 1-3. Please consult Appendix B: problem solving.

3. CONFIGURATION

3.1. INTRODUCTION

This and the following chapters are exclusively meant for electricians and non-operators. In these, an extensive description of all software settings and hardware connections are provided.



- **Mounting, electrical installation, start-up and maintenance of the instrument may only be carried out by trained personnel authorized by the operator of the facility. Personnel must read and understand this Operating Manual before carrying out its instructions.**
- **The F130-P may only be operated by personnel who are authorized and trained by the operator of the facility. All instructions in this manual are to be observed.**
- **Ensure that the measuring system is correctly wired up according to the wiring diagrams. The housing may only be opened by trained personnel.**
- **Take careful notice of the " Safety rules, instructions and precautionary measures " in the front of this manual.**

3.2. PROGRAMMING SETUP-LEVEL

3.2.1. GENERAL

Configuration of the F130-P is done at SETUP-level. SETUP-level is reached by pressing the PROG/ENTER key for 7 seconds; at which time, both arrows ▼ will be displayed. In order to return to the operator level, PROG will have to be pressed for three seconds. Alternatively, if no keys are pressed for 2 minutes, the unit will exit SETUP automatically. SETUP can be reached at all times while the F130-P remains fully operational.



Note: A pass code may be required to enter SETUP. Without this pass code access to SETUP is denied.

To enter SETUP-level:

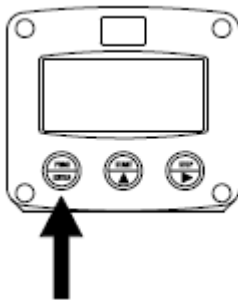

Press  for 7 seconds

Matrix structure SETUP-level:

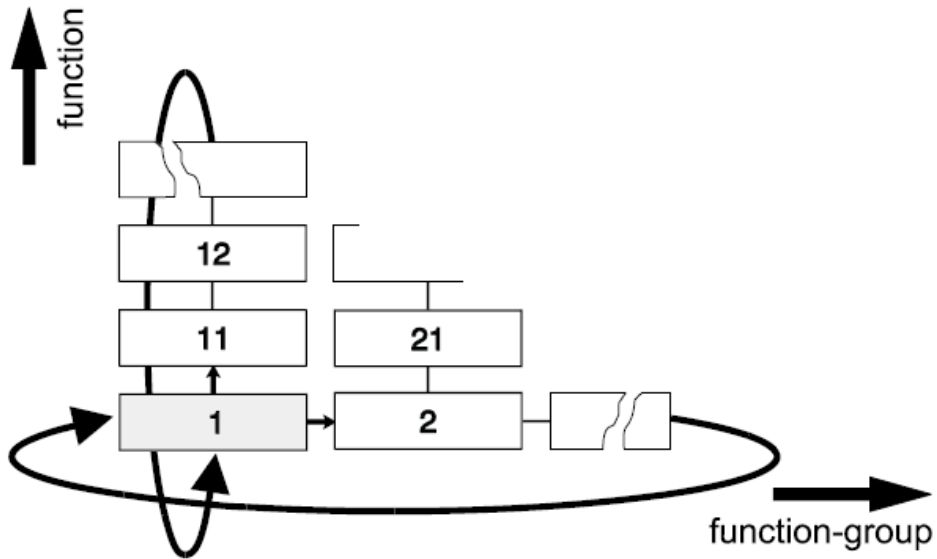

SCROLLING THROUGH SETUP-LEVEL

Selection of function-group and function:

SETUP is divided into several function groups and functions.

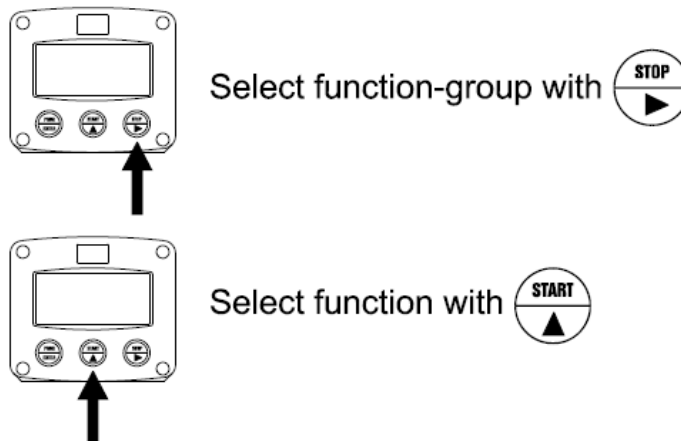



Each function has a unique number, which is displayed below the word "SETUP" at the bottom of the display. The number is a combination of two figures. The first figure indicates the function-group and the second figure the sub-function. Additionally, each function is expressed with a keyword.

After selecting a sub-function, the next main function is selected by scrolling through all "active" sub-functions (e.g. 1 * : 1 1 * , 1 2 " , 1 3 * , 1 4 * . 1 ► , 2 ► , 3 * , 3 1 etc.).

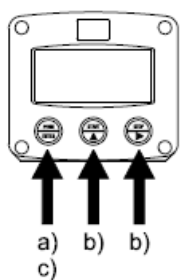

To change or select a value:



a) press  briefly; **PROGRAM** will start flash

b) select or enter value with  and / or 

c) press  to confirm the value / selection.

To change a value, use  to select the digits and * to increase that value. To select a setting, both * and  can be used.

If the new value is invalid, the increase sign* or decrease-sign ^T will be displayed while you are programming.

When data is altered but ENTER is not pressed, then the alteration can still be cancelled by waiting for 20 seconds or by pressing ENTER for three seconds: the PROG-procedure will be left automatically and the former value reinstated.



Note: alterations will only be set after ENTER has been pressed!

Note !

To return to OPERATOR-level:

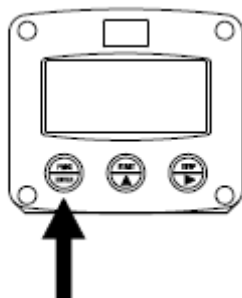

Press  for 3 seconds

In order to return to the operator level. PROG will have to be pressed for three seconds. Also, when no keys are pressed for 2 minutes, SETUP will be left automatically.

3.2.2. OVERVIEW FUNCTIONS SETUP LEVEL

SETUP FUNCTIONS AND VARIABLES			
1	PRESET		
	11	UNIT	L - rn3 - kg - lb - GAL - USGAL - bbl - no unit
	12	DECIMALS	0 - 1 - 2 - 3 (Ref: displayed value)
	13	K-F ACTOR:	0.000010 - 9.999.999
	14	DECIMALS K-FACTOR	0 - 6
	15	BATCH MAXIMUM	X,XXX. XXX quantity
2	OVERRUN		
	21	OVERRUN	disable-enable
	22	TIME	0.1 -999.9 seconds
3	ALARM		
	31	NO-FLOW ALARM	disable - enable
	32	NO-FLOW TIME	0.1 - S9S.9 seconds
4	DISPLAY		
	41	DISPLAY	increase - decrease
5	POWER MANAGEMENT		
	51	LCD UPDATE	fast-1 sec- 3 sec-15 sec-30 sec-off
	52	BATTERY MODE	operational-shelf
6	FLOWMETER		
	61	SIGNAL	npri - npnpj - reed - reedjp - pnp - pnpjp - namur - coiljii -coil
7	RELAYS		
	71	RELAYS	1-step.' 2-step
	72	PRECLUDE	X,XXX. XXX quantity
	73	PERIOD TIME	0-250
	74	IMPULSE PER	X.XXX.XXX quantity
	75	IMPULSE ACCORDING	total - batch
8	COMMUNICATION		
	81	SPEED/BAUDRATE	1200-2400-4800 - 9600
	82	ADDRESS	1 -255
	83	MODE	ASCII -rtu- off
9	OTHERS		
	91	TYPE /MODEL	
	92	SOFTWARE VERSI OM	
	93	SERIAL NO.	
	94	PASSWORD	0000 - 9999
	95	TAGNUMBER	0000000 - 9999999

3.2.3 EXPLANATION OF SETUP-FUNCTIONS

1 – PRESET	
MEASUREMENT UNIT 11	<p>SETUP - 11 determines the measurement unit for preset, total, accumulated total and pulse output. The following units can be selected: L - m3 - kg - lb. - GAL - USGAL - bbl - _ (no unit). Alteration of the measurement unit will have consequences for operator and SETUP-level values. Please note that the K-factor has to be adapted as well; the calculation is not done automatically.</p>
DECIMALS 12	<p>The decimal point determines for preset, total, accumulated total and pulse output the number of digits following the decimal point. The following can be selected: 0000000 - 11 1111.1 - 22222.22 - 3333.333</p>
K-FACTOR 13	<p>With the K-factor, the flowmeter pulse signals are converted to a quantity. The K-factor is based on the number of pulses generated by the flowmeter per selected measurement unit (SETUP 11), for example per cubic meter. The more accurate the K-factor, the more accurate the functioning of the system will be.</p> <p>Example 1 : Calculating the K-factor. Let us assume that the flowmeter generates 2.4813 pulses per liter and the selected unit is "cubic meters / m3". A cubic meter consists of 1000 parts of one liter which implies 2.481.3 pulses per m3. So, the K-factor is 2,481.3. Enter for SETUP-13: 2481300" and for SETUP -14- decimals K-factor 3</p> <p>Example 2 : Calculating the K-factor. Let us assume that the flowmeter generates 6.5231 pulses per gallon and the selected measurement unit is gallons. So, the K-Factors 6.5231. Enter for SETUP-13: "6523100" and for SETUP -14 decimals K-factor "6".</p>
DECIMALS K-FACTOR 14	<p>This setting determines the number of decimals for the K-factor entered. (SETUP 13). The following can be selected :0-1-2-3-4-5-6 Please note that this setting influences the accuracy of the K-factor indirectly, (i.e. the position of the decimal point and thus the value given) This setting has NO influence on the displayed number of digits for total (SETUP 12)!</p>
BATCH MAXIMUM 15	<p>This function limits the operator to enter a new preset - value which is more as the entered batch maximum.</p>
2 - OVERRUN	
<p>Overrun can occur at the end of the batch process, as a result of slowness of a valve pump. Consequently, the accuracy is less. With this function, the F130-P analyses the actual overrun characteristic after every batch. This information is used to correct the overrun automatically.</p>	
OVERRUN 21	<p>For an accurate overrun correction, it is necessary that the flow meter meets certain technical demands, such as "high resolution" and shows no "false" overrun due to a slow update time. Do not enable this function if the flow meter does not meet these technical demands.</p>
OVERRUN TIME 22	<p>The overrun characteristic of the system will be analyzed during a certain time after the batch. In this way, false signal generated through leakage are eliminated. Enter here the expected time needed by the system to stop a batch. It is advisable to provide extra time in order to avoid an incorrect overrun correction or false leakage alarms. Note that the next batch can only be started after elapsing of this overrun time! The minimum overrun time is 0.1 second, maximum 999.9 seconds.</p>
3 - ALARM	
<p>The F130-P offers a no-flow alarm feature: if the flowmeter fails to generate a signal during a certain period of time, the unit will shut-off the control output(s) and bring the batch controller in alarm status. After eliminating the alarm, the batch can be continued or denied</p>	
NO-FLOW ALARM 31	<p>With this function, the no-flow monitoring can be enabled /disabled.</p>
NO-FLOW TIME 32	<p>In case of a failing signal, this function determines the period of time after which an alarm has to be triggered. The minimum overrun time is 0.1 second, maximum 999.9 seconds.</p>

4 - DISPLAY

DISPLAY 41	The large 17mm digits can be set to display the actual batched quantity (increase) OR to display the remaining quantity to be batched (decrease).
-------------------	---

5 - POWER MANAGEMENT

When used with the internal battery option, the user can expect reliable measurement over a long period of time. The F130-P has several smart power management functions to extend the battery life time significantly. Two of these functions can be set:

LCD NEW 51	<p>The calculation of the display-information influences the power consumption significantly. When the application does not require a fast display update, it is <u>strongly advised</u> to select a slow refresh rate. Please understand that NO information will be lost; every pulse will be counted and the output signals will be generated in the normal way. The following can be selected: Fast - 1 sec - 3 sec - 15 sec - 30 sec - off.</p> <p>Example: Battery life-time</p> <p style="padding-left: 40px;">with a coil pick-up, 1KHz. pulses, FAST update: about 2 years,</p> <p style="padding-left: 40px;">with a coil pick-up, 1KHz. pulses, 1 sec update: about 5 years.</p> <p>Note: after a button has been pressed by the operator - the display refresh rate will always switch to FAST for 30 seconds.</p>
BATTERY-MODE 52	<p>The unit has two modes: operational or shelf.</p> <p>After "shelf" has been selected, the unit can be stored for several years; it will not count pulses, the display is switched off but all settings and totals are stored. In this mode, power consumption is extremely low. To wake up the unit again, press the SELECT-key twice.</p>

6 - FLOWMETER

SIGNAL 61	The F130-P is able to handle several types of input signal. The type of flowmeter pickup / signal is selected with SETUP 61. <i>Note: The selections "active pulse" offer a detection level of 50% of the supply voltage.</i> Read also par. 4.4.3. Flowmeter input terminal 09-11.			
TYPE OF SIGNAL	EXPLANATION	RESISTANCE	FREQ./MV	REMARK
NPN	NPN input	100K pull-up	6 kHz.	(open collector)
NPN-LP	M PN input with low pass filter	100K pull-up	2.2 kHz.	(open collector) less sensitive
REED	Reed-switch input	1M pull-up	1.2 kHz.	
REED- L P	Reed-switch input with low pass filter	1M pull-up	120 Hz.	Less sensitive
PNP	PNP input	100K pull-down	5 kHz.	
PNP-LP	PNP input with low pass filter	100K pull-down	700 Hz.	Less sensitive
NAMUR	Namur input	820 Ohm pull-down	4 kHz.	External power required
COIL HI	High sensitive coil input	-	20mV P-tp	Sensitive for disturbance!
COIL LO	Low sensitive coil input	-	90mV p.tp.	Normal sensitivity
ACTJ.1	Active pulse input 8.1 VDC	3K9	10KHz.	External power required
ACTJ2	Active pulse input 12 VDC	4K	10KHz.	External power required
ACT.24	Active pulse input 24 VDC	3 K	10KHz.	External power required

7 - RELAY OUTPUT

Two control outputs are available to control relays or valves. Relay 2 can also be used as pulse output according the batch total (actual) or accumulated total.			
1-STEP/2-STEP 71	With this setting, the function of relay is <i>Select "2-step" to executed batches with a two-stage valve. Select "1-step" to be able to use relay 2 as pulse output relay.</i>		
PRECLUSE QUANTITY 72	According to the setting 71 - 2-step, relay two will be used to control a valve for the batch process. If the product is batched in two steps, the switch-off-moment for relay 2 has to be set. The switch moment is based on the remaining quantity before the end of batch. If the pre close is set to zero, it will switch simultaneously with relay 1.		
PERIOD TIME PULSE OUTPUT 73	According to setting 71 "1-step", relay 2 can be used as a pulse output. The period time determines the time that the transistor or relay will be switched; in other words the pulse length. The minimum time between the pulses is as long as the period time. One period is approx. 7.8 msec. If the value selected is "zero", the pulse output is disabled. The maximum value is 255 periods. Note: If the frequency should go out of range - when the flowrate increases for example - an internal) buffer will be used to "store the missed pulses": As soon as the flowrate reduces again, the buffer will be "emptied".It might be that pulses will be missed due to a buffer-overflow, so it is advised to program this setting within it's range		
	NUMBER OF PERIODS	PERIOD TIME	MAX. FREQUENCY
	0	disabled	disabled
	1	0,0078 seconds	64 Hz.
	2	0,0156 seconds	32 Hz.
	64	0,5000 seconds	1 Hz.
	255	1,9922 seconds	0.25 Hz.
PULSE PER 74	According to the measurement unit settings for preset a scaled pulse will be generated every X-quantity. Enter this quantity here while taking the displayed decimal position and measuring unit into account.		
PULSE ACCORDING ACC.TOTAL /BATCH 75	With this function, it is determined if a pulse will be generated according the quantity batched or according accumulated total. With setting "batch" the pulse generator will be set to zero when a new batch is started up.		

8 - COMMUNICATION {OPTIONAL}

The functions described below deal with hardware that is not part of the standard delivery. Programming of these functions does not have any effect if this hardware has not been installed. Consult Appendix C and the Modbus communication protocol description for a detailed explanation.	
BAUDRATE 81	For external control, the following communication speeds can be selected: 1200- 2400 -4600- 9600 baud
BUS ADDRESS 82	For communication purposes, a unique identity can be attributed to every F130-P. This address can vary from 1-255.
MODE 83	The communication protocol is Modbus ASCII or RTU mode. Select OFF, to disable this communication function.

9 - OTHERS

TYPE OF MODEL 91	For support and maintenance: provide this information to your supplier.
VERSION SOFTWARE 92	For support and maintenance: provide this information to your supplier.
SERIAL NUMBER 93	For support and maintenance: provide this information to your supplier.
PASS CODE 94	All SETUP-values can be pass code protected. This protection is disabled with value 0000 (zero). 4 digits can be programmed, for example 1234.
TAGNUMBER 95	For identification of the unit and communication purposes, a unique tag number of maximum 7 digits can be entered.

4. INSTALLATION

4.1. GENERAL DIRECTIONS

- Mounting, electrical installation, start-up and maintenance of this instrument may only be carried out by trained personnel authorized by the operator of the facility. Personnel must read and understand this Operating Manual before carrying out its instructions.
- The F130-P may only be operated by personnel who are authorized and trained by the operator of the facility. All instructions in this manual are to be observed.
- Ensure that the measuring system is correctly wired up according to the wiring diagrams. Protection against accidental contact is no longer assured when the housing cover is removed or the panel cabinet has been opened (danger from electrical shock). The housing may only be opened by trained personnel.
- Take careful notice of the " Safety rules, instructions and precautionary measures " at the front of this manual.

4.2. INSTALLATION / SURROUNDING CONDITIONS

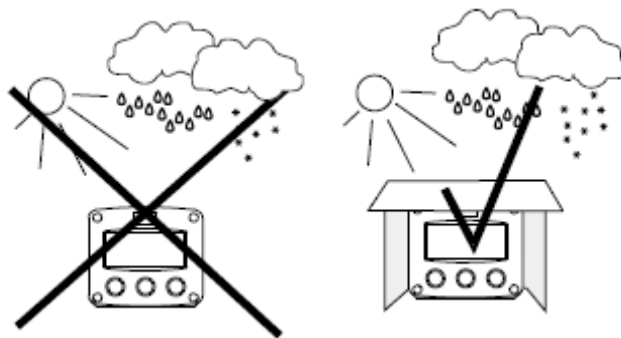

Take the relevant IP classification of the casing into account (see manufactures plate). Even an IPB7 (NEMA 4X) casing should NEVER be exposed to strongly varying (weather) conditions. When panel-mounted, the unit is IP65 (NEMA 4)!

When used in very cold surroundings or varying climatic conditions, take the necessary precautions against moisture by placing a dry sachet of silica gel, for example, inside the instrument case.

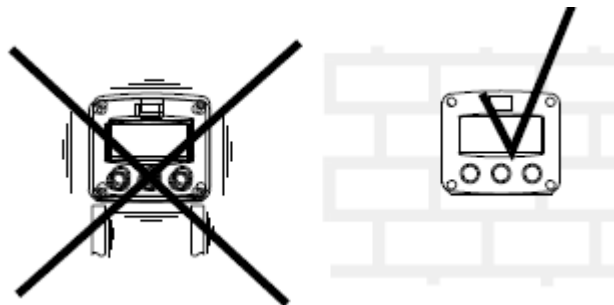

Mount the F-130 on a solid structure to avoid vibrations

4.3 DIMENSIONS ENCLOSURES

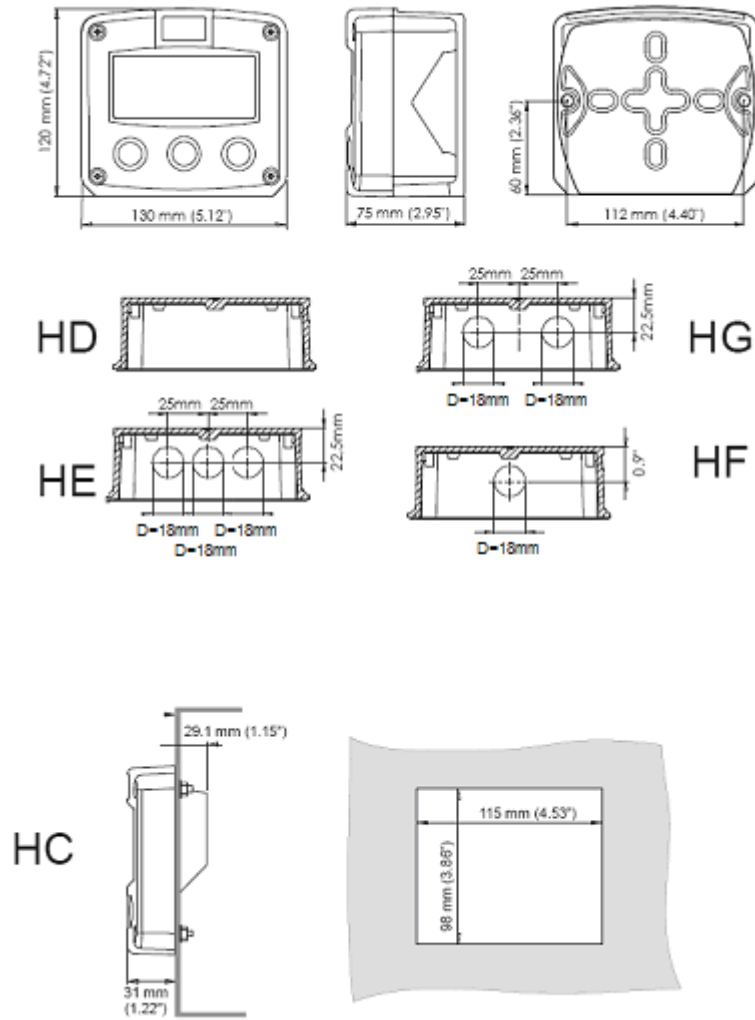

Fig. 8: Dimensions GRP enclosures.

4.4 INSTALLING THE HARDWARE

4.4.1. INTRODUCTION

- Electro static discharge does inflict irreparable damage to electronics! Before installing or opening the unit, the installer has to discharge himself by touching a well-grounded object.
- This unit must be installed in accordance with the EMC guidelines (Electro Magnetic Compatibility).
- Do ground the aluminum casing property as indicated, if the F130-P has been supplied with the 115-230VAC power-supply type PM. The green / yellow wire between the back-casing and removable terminal-block may never be removed.

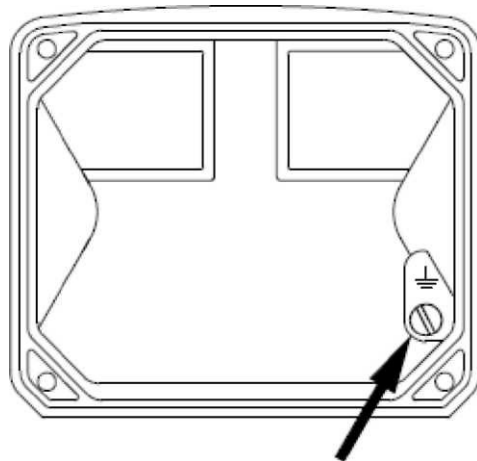

Fig. 9: Grounding aluminum enclosure with type PM 115-230V A.C.

FOR INSTALLATION, PAY EMPHATIC ATTENTION TO:

- Separate cable glands with effective IP67 (NEMA4X) seals for all wires.
- Unused cable entries: ensure that you fit IP67 (NEMA4X) plugs to maintain rating.
- A reliable ground connection for both the sensor, and if applicable, for the metal casing, (above)
- An effective screened cable for the input signal, and grounding of it's screen to terminal 9 (GND) or at the sensor itself, whichever is appropriate to the application.

4.4.2. VOLTAGE SELECTION SENSOR SUPPLY

Type PB / PC / PX (AP) - battery powered and output loop-powered applications:

Terminal 11 provides a limited supply voltage of 3.2 V DC (coil signals 12V) for the signal output of the flowmeter.

Note: This voltage MAY NOT be used to power the flowmeters electronics, converters etc, as it will not provide adequate sustained power! All energy used by the flowmeters pick-up will directly influence the battery life-time. It is strongly advised to use a "zero power" pickup such as a coil or reed-switch when operating without external power. It is possible to use some low power NPN or PNP output signals, but the battery life time will be significantly reduced (consult your distributor)

Type PD / PF / PM: Sensor supply: 1,2 - 3.2V - 8.2V - 12V or 24 V DC:

With this option, a real power supply for the sensor is available. The flowmeter can be powered with 8.2 - 12 or 24 V DC.

Total power consumption PD: max. 50mA@24V and PF / PM: max. 400mA@24V.

The voltage is selected with the three switches inside the enclosure

- **Warning: be sure that all the leads to the terminals are disconnected from the unit when the internal plastic protection cover has been removed !**
- **HIGH VOLTAGE 400V !! NEVER connect the mains power supply to the unit when the plastic protection cover has been removed !!!**

First, remove the terminal strip(s) after which the internal plastic cover can be removed. The switches are located in the top left corner (type PD) or on the right hand (type PF / PM) as indicated:

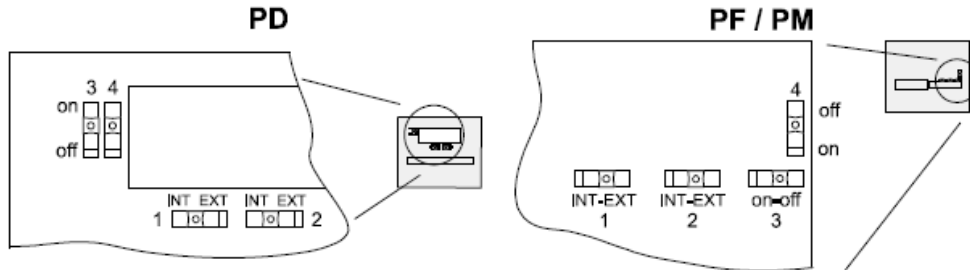

Fig. 10: Switch setting sensor supply voltage.

Switch positions

SENSOR A	
SWITCH 1	VOLTAGE
internal	3.2 VDC
external	switch 3+4

SENSOR B	
SWITCH 2	VOLTAGE

VOLTAGE SELECTION		
SWITCH 3	SWITCH 4	VOLTAGE
on	on	8.2 V DC
on	off	12 V D C
off	off	23 V DC

Function switch 1 : voltage selection sensor A - terminal 11.

Function switch 2: not available for this Model.

Function switch 3+4: the combination of these switches determine the voltage as indicated.

Do move switch 1 and / or switch 2 to the OFF position to enable the selected voltage with switch 3+4.

4.4.3. TERMINAL CONNECTORS

The following terminal connectors are available:

POWER SUPPLY TYPE PD / PF / PM			TWO-STAGE or PULSE OUTPUT R 2 TYPE OA / OT / OR		BATCH OUTPUT R 1 TYPE OA / OT / OR		POWER SUPPLY TYPE PX 8-30V DC		SENSOR SIGNAL PULSE INPUT TYPE P			START INPUT		STOP INPUT		
GND	1	2	3	4	5	6	7	8	9	10	11	12	13	14	15	16
⊥	N	L1	R2 ⊥	R2	R1 ⊥	R1	⊥	+I	⊥	SIGNAL	+I	⊥	START		⊥	STOP

Fig 11. Overview of terminal connectors standard configuration F130-P and options.

REMARKS: TERMINAL CONNECTORS:

Terminal GND- 01- 02: Power Supply - only available with type PD / PF or PM:

TYPE	SENSOR SUPPLY	Terminal			backlight	TYPE AA	TYPE AU	Type OA	Type OR
		GND	01	02					
PD 8-24V AC	8,2 / 12 / 24V max. 50mA		AC	AC	◇	◇	◇	◇	
PD 8-30V DC	8,2 / 12 / 24V max. 50mA	L-	L+		◇	◇	◇	◇	
PF 24V AC ± 15%	8,2 / 12 / 24V max. 400mA		AC	AC	◇	◇	◇	◇	◇
PF 24V DC ± 15%	8,2 / 12 / 24V max. 400mA	L-	L+		◇	◇	◇	◇	◇
PM 115-230V AC ± 15%	8,2 / 12 / 24V max. 400mA	EARTH	AC	AC	◇	◇	◇	◇	◇
Note PD	do not use a AC autotransformer (Spartrafo) without a galvanic isolation.								
Note PF / PM	The total consumption of the sensors and outputs may not exceed 400mA@24V								

◇=option



Note: for power supply type PX: please read Terminal 07-08

Terminal 03-04; control or pulse output R2:

This output is available to control the batch process for two-step control or as pulse output. In case of a pulse output function: the maximum pulse frequency of this output is 60 Hz.

Terminal 05-06; control output R1:

This output is available to control the batch process. Relay 1 is switched-on during the whole batch process.

Type OA; :

An active 24V DC signal according to the functions R1 and R2 is available with this option. Max. driving capacity 50mA@24V per output. (Requires power supply type PD / PF / PM).

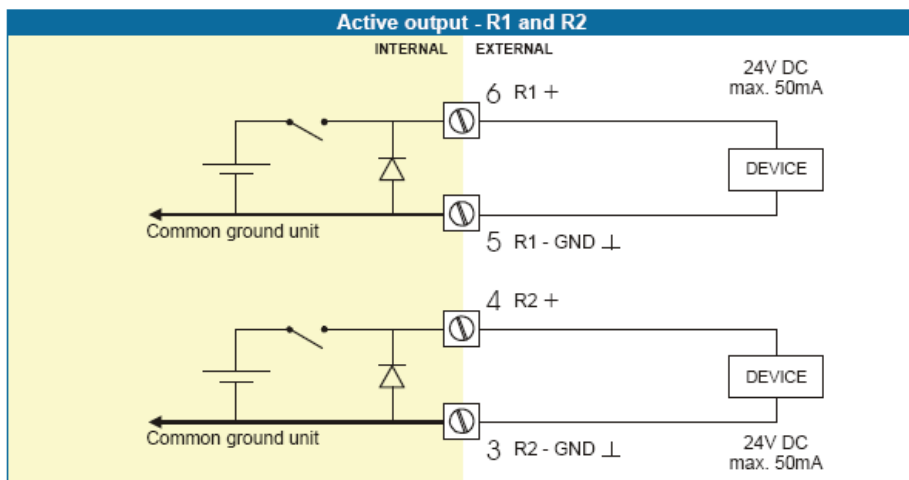

Type OR: :

A mechanical relay output according the functions R1 and R2 is available with this option. Max. switch power 240V-0,5A per output. (Requires power supply type PF / PM).

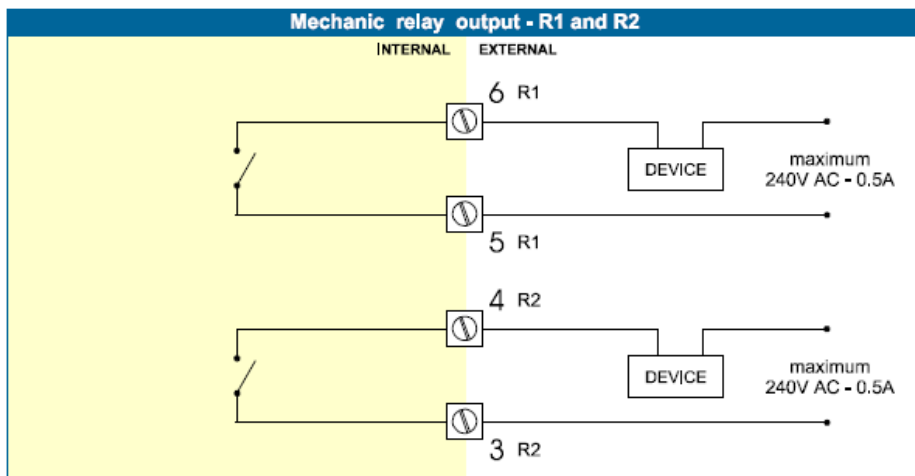

Type OT:

A passive transistor output is available with this option. Max. driving capacity 300mA@50V DC.

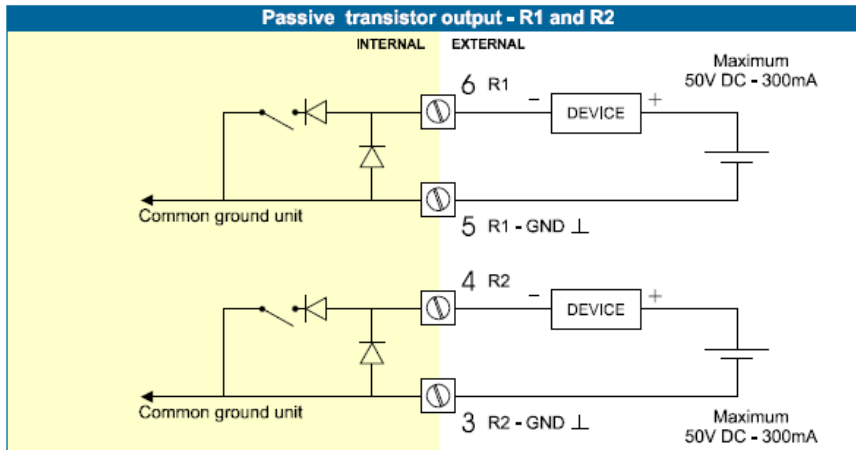

Terminal 07-08; basic POWER SUPPLY - type PX.

Connect an external power supply of 8-30VDC to these terminals; the "-" to terminal 7 and the "+" to terminal 8. When power is applied to these terminals, the (optional) internal battery will be disabled / enabled automatically to extend the battery life time.

Terminal 09-11; Flowmeter input:

Three basic types of flowmeter signals can be connected to the unit: pulse, active pulse or sine-wave (coil). The screen of the signal wire must be connected to the common ground terminal 09 (unless earthed at the sensor itself).

The maximum input frequency is approximately 10 kHz (depending on the type of signal). The input signal type has to be selected with the correct SETUP-function (read par. 3.2.3.)

Sine-wave signal (Coil):

The F130-P is suitable for use with flowmeters which have a coil output signal. Two sensitivity levels can be selected with the SETUP-function:

COIL LO: sensitivity from about 120mVp-p.

COIL HI: sensitivity from about 20mVp-p. Type ZF offers for

Type ZF offers for setting COIL HI : sensitivity from about 10mVp-p.

Type ZG offers for setting COIL HI : sensitivity from about 5mVp-p.

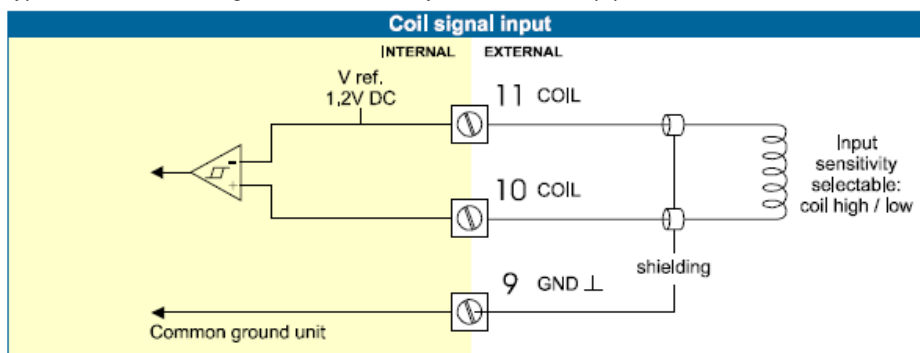

Pulse-signal NPN/NPN-LP:

The F130-P is suitable for use with flowmeters which have a NPN output signal. For reliable pulse detection, the pulse amplitude has to go below 1.2V. Signal setting NPN-LP employs a low-pass signal noise filter, which limits the maximum input frequency - read par. 3.2.3.

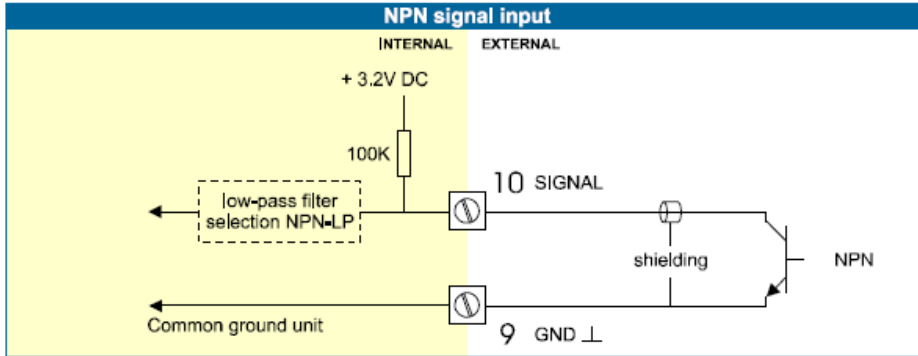

Pulse-signal PNP / PNP-LP:

The F130-P is suitable for use with flowmeters which have a PNP output signal. 3.2V is offered on terminal 11 which has to be switched by the sensor to terminal 10 (SIGNAL). For a reliable pulse detection, the pulse amplitude has to go above 1.2V. Signal setting PNP-LP employs a low-pass signal noise filter, which limits the maximum input frequency - read par. 3.2.3. A sensor supply voltage of 6.1, 12 or 24V DC can be provided with power supply type PD, PF, PM. For a signal detection level of 50% of the supply voltage: please refer to "active signals" .

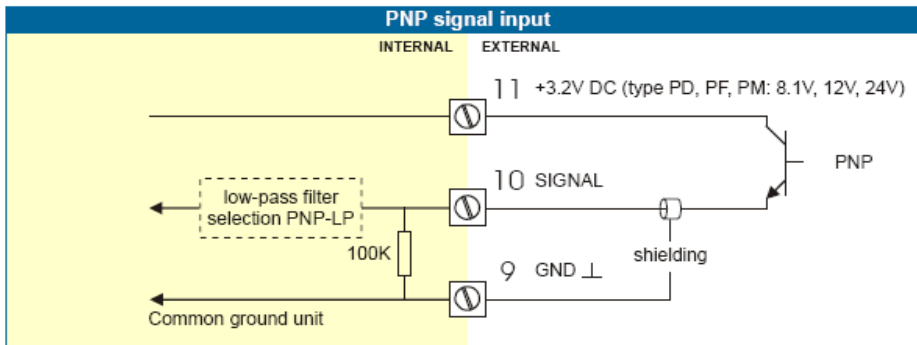

Active signals 6.1V - 12V and 24V:

If a sensor gives an active signal, please read par. 3.2.3. The detection levels are 50% of the selected supply voltage; approximately 4V (ACT_6.1) or 6V (ACT_12) or 12V (ACT_24). Active signal selection may well be desired in the case of power supply type PD, PF, PM being supplied for sensor supply.

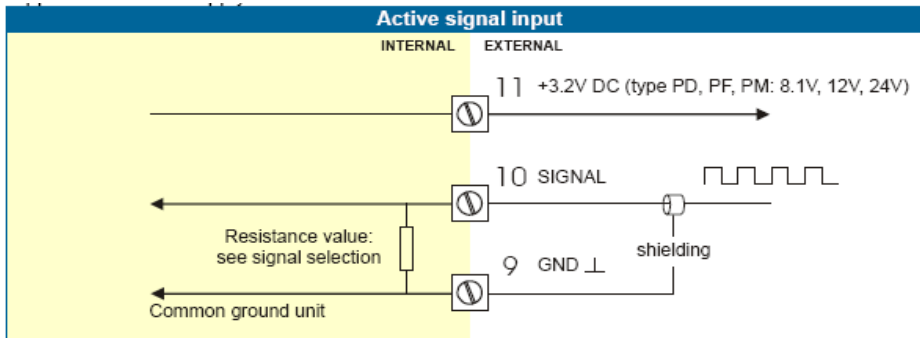

Reed-switch:

The F130-P is suitable for use with flowmeters which have a reed-switch. To avoid pulse bounce from the reed-switch, it is advised to select REED LP - low-pass filter (read par. 3.2.3.)

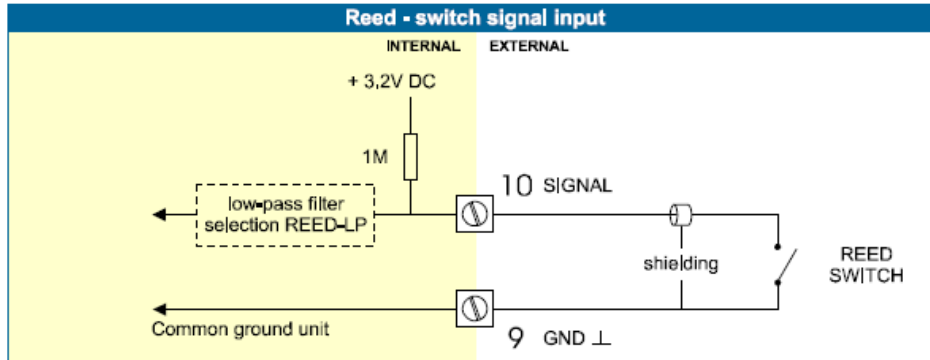

NAMUR-skjnal:

The F130-P is suitable for flowmeters with an Namur signal. The standard F130-P is not able to power the Namur sensor, as an external power supply for the sensor is required. However, a 8.2 V sensor supply voltage (terminal 11) can be provided with power supply type PD, PF, PM.

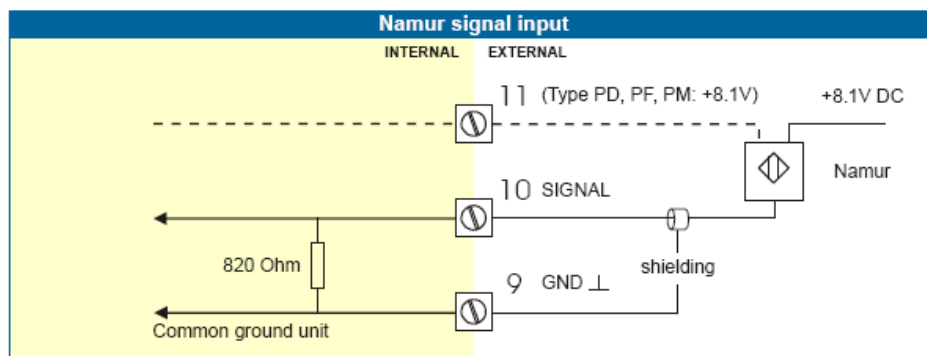

Terminal 12-13; external START:

With this function, the batch controller can be started with an external switch. The input must be switched with a potential free contact to the GND-terminal number 12 for at least 0.3 seconds.

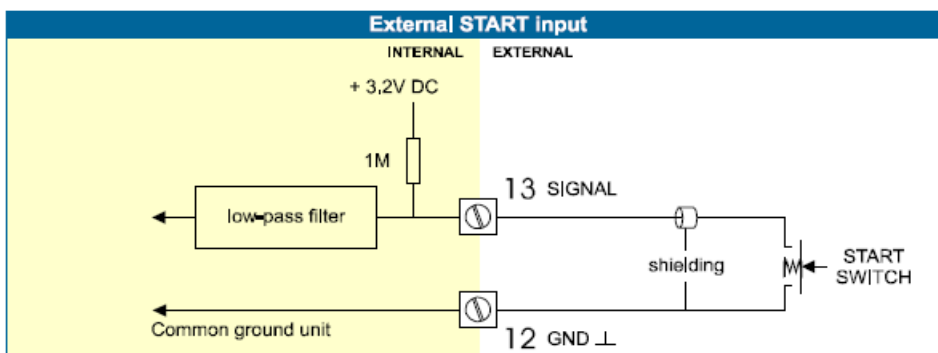

Terminal 15-16; external STOP:

With this function, the batch controller can be interrupted or cancelled with an external switch. The input must be switched once for interruption or switch twice for cancellation with a potential free contact to the GND-terminal number 15 for at least 0.3 seconds.

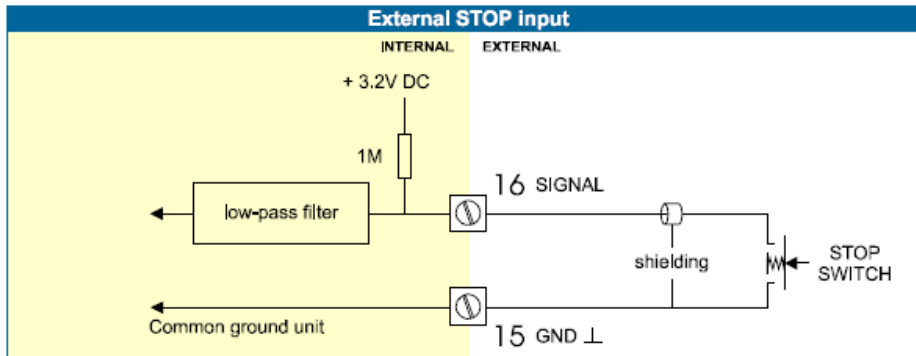

Terminal 26-31 ; type CB / CH | CI | CT - communication RS232 / RS4&5 / TTL (option]

- Full serial communications and computer control in accordance with RS232 (length of cable max. 15 meters) or RS485 (length of cable max. 1200 meters) is possible.
- Read the Modbus communication protocol and Appendix C.

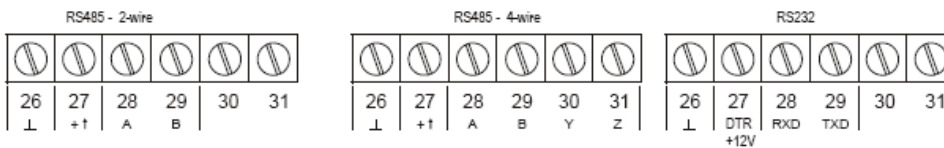

Fig. 12: Overview terminal connectors communication option.

When using the RS232 communication option, terminal 27 is used for supplying the interface. Please connect the DTR (or the RTS) signal of the interface to this terminal and set it active (+12V). If no active signal is available it is possible to connect a separate supply between terminals 26 and 27 with a voltage between 8V and 24V.

Terminal 26-31 ; backlight - type ZB (option):

Note: if the unit is supplied with a power supply type PD. PF or PM, the backlight supply is integrated, so the text following is not applicable.

To power the backlight, provide a 12-24V DC to terminal 26 (-) and 27 (+). An external trimmer 1 kOhm can be used to tune the brightness of the backlight, or if not desired, a short-cut between these terminals have to be made which will result in the maximum brightness.

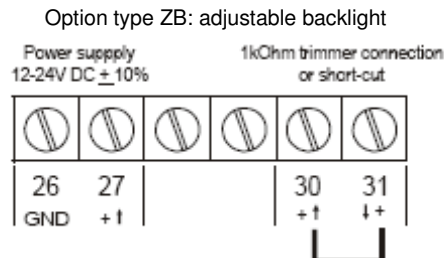

Fig. 13: Overview terminal connectors backlight option.

5. MAINTENANCE

5.1. GENERAL DIRECTIONS

- **Mounting, electrical installation, start-up and maintenance of the instrument may only be carried out by trained personnel authorized by the operator of the facility. Personnel must read and understand this Operating Manual before carrying out its instructions.**
- **The F130-P may only be operated by personnel who are authorized and trained by the operator of the facility. All instructions in this manual are to be observed.**
- **Ensure that the measuring system is correctly wired up according to the wiring camon i diagrams. Protection against accidental contact is no longer assured when the housing cover is removed or the panel cabinet has been opened (danger from electrical shock). The housing may only be opened by trained personnel.**
- **Take careful notice of the" Safety rules, instructions and precautionary measures " in the front of this manual.**

The F-130 does not require special maintenance unless it is used in low temperature applications or surroundings with high humidity (above 90% annual mean). It is the users responsibility to take all precautions to dehumidify the internal atmosphere of the F130-P in such a way that no condensation will occur, for example by placing dry silica-gel sachet in the casing just before closing it. Furthermore, it is required to replace or dry the silica gel periodically as advised by the silica gel supplier.

Battery life-time:

It is influenced by several issues :

- Type of sensor: read chapter 3.2.3. NPN and PNP inputs consume more energy than coil inputs.
- Input frequency: the higher the frequency, the shorter the battery life-time.
- Display update: fast display update uses significantly more power; **SETUP 51**.
- Pulse output and communications .
- Low temperatures; the available power will be less due to battery chemistry.



Note: *It is strongly advised to disable unused functions.*

Check periodically:

- The condition of the casing, cable glands and front panel.
- The input/output wiring for reliability and aging symptoms.
- The process accuracy. As a result of wear and tear, re-calibration of the flowmeter might be necessary. Do not forget to re-enter any subsequent K-factor alterations.
- T h e i n d i c a t i o n f o r l o w - b a t t e r y .
- Clean the casing with soapy-water. Do not use any aggressive solvents as these might damage the coating.

6.2. REPAIR

This product cannot be repaired by the user and must be replaced with an equivalent certified product. Repairs should only be carried out by the manufacturer or his authorized agent.

APPENDIX : PROBLEM SOLVING

In this appendix, several problems are included that can occur when the F130-P is going to be installed or while it is in operation.

Flowmeter does not generate pulses:

Check:

- Signal selection SETUP-61
- Pulse amplitude (par. 4.4.3.).
- Flowmeter, wiring and connection of terminal connectors (par. 4.4.3.),
- Power supply of flowmeter (par. 4.4.2.).

Flowmeter generates "too many pulses":

Check:

- Settings for total: SETUP 11-14,
- Type of signal selected with actual signal generated - SETUP - 61 ;
- Sensitivity of coil input - SETUP - 61 and par. 4.4.3.
- Proper setting of the FI 3Q-P and flowmeter - par. 4.4.1.

Pulse output does not function:

Check:

- SETUP 71 - pulse per "x" quantity; is the value programmed reasonable and will the maximum output be under 20Hz?
- SETUP 72 - impulse width; is the external device able to recognize the selected pulse width and frequency?

The pass code is unknown:

If the pass code is not 1234, there is only one possibility left: call your supplier.

ALARM

When the alarm flag starts to blink an internal alarm condition has occurred. Press the "select button" several times to display the 5-digit error code. The codes are:

0001: irrecoverable display-data error: data on the display might be corrupted.

0002: irrecoverable data-storage error: the programming cycle might have gone wrong: check programmed values.

0003: error 1 and error 2 occurred simultaneously

The alarm condition will almost certainly be handled internally and if all mentioned values still appear correct, no intervention by the operator is needed. If the alarm occurs more often or stays active for a longer time, please contact your supplier.