

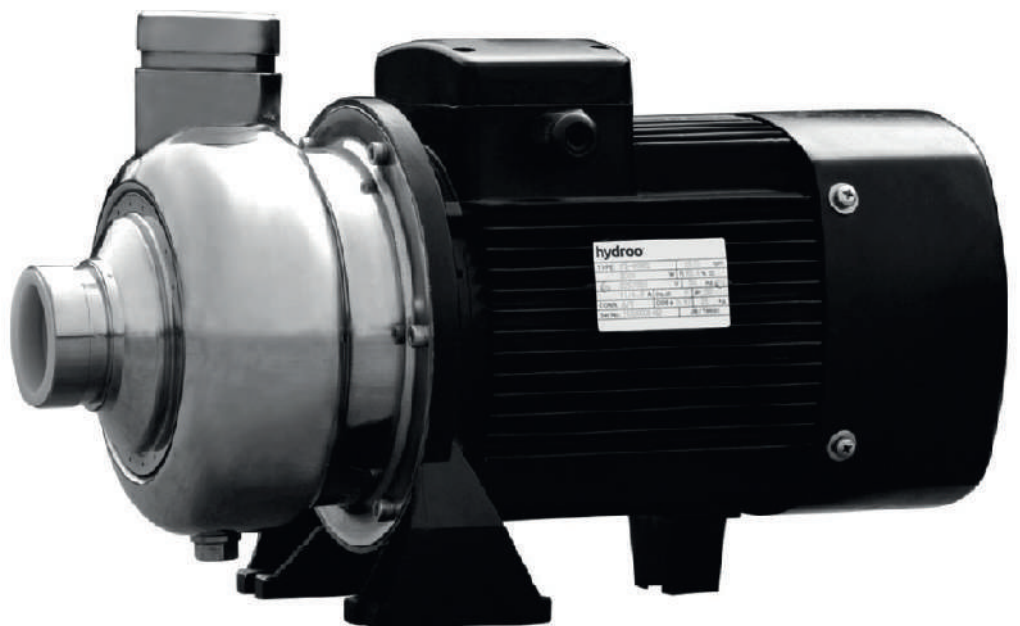

We Make The Difference

MXO-MXC MDROO Series

Horizontal
single-stage
centrifugal pump



hydroo®



HYDROO is present in all the European markets by means of a distribution network focused on the service and the valuation of the pumping business. HYDROO conceives, researches, develops, designs, industrializes, and manufactures a wide range of pumping solutions for the most demanding applications in industrial markets, irrigation, water supply and water treatment as well as in residential and commercial buildings. The values of operational excellence, experience, reliability, and passion for a well-done job guide the daily work of the Hydroo team together with our partners and distributors. The global challenges of water management require excellence in pumping technologies and a joint effort between designers, manufacturers, and pumping engineers. To meet the needs of the market in the more demanding installations Hydroo is firmly committed to manufacturing the best pumping equipment on the market following and sharing our values worldwide.

The Hydroo values are presented in 5 great concepts that we summarize in our motto Hy5, which are our principles and commitments:

BE PUMPING PARTNERS

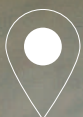

Gorga d'en Duran, Sant Feliu de Pallerols
(Garrotxa county, Catalonia)

Amazing natural pool created in-between the course of the Brugent river which includes beautiful waterfalls. In middle of a lush, humid and green forest, reminiscent of tropical forests, they are of incredible beauty and give off an immense peace.

Coordinates:
Longitude: 2.5289261
Latitude: 42.0646390



hymotion

Value proposal based on the reliability of products enhancing the quality, the development of efficient supply chains, the productivity with the love of craftsmen at every step of the manufacturing and production lines. We move with the commitment to improve pumping systems, make them more efficient, more reliable, more digitized, more at the service of the human development.



hylite

Contribution to preservation of the environment and to sustainability. We reduce the environmental impact and footprint of carbon. We contribute to the development of the circular economy. Our team stand out for the highest standards of energy efficiency.



hyefficient

The use of the most advanced analytical, development and simulation tools allows us to optimize our R&D teamwork results. We maximize the study of materials, efficient hydraulics, mechanical improvements and the optimization of our motors up to 200 kW. The results are robust, reliable, flexible, adjustable, multipurpose, and user-friendly pumping equipment.



hynovative

Commitment to implementation of the innovation process as strategic pillar of the company. Transfer new ideas to realities that evolve pumping industry and internalize the process in each job position to offer market improvements.



hyliance

We are the factory of our customers. Without solution of continuity between the value chain starting in the components production plants and ending with amortization of the pumping equipment operating at full performance for years and giving satisfaction to distributors, project engineers and pumping systems managers. We make real our catchphrase **Be Pumping Partners**.

MXO MXC

Horizontal
single-stage
centrifugal pump

Description

Single stage pump, monobloc version, made of AISI304 SS with open (MXO) or close impeller (MXC) available for demanding applications with temperatures between -10 °C and +70 °C.

Single stage version also available up to 2,2 kW.

Performance range

Flow rate: up to 45 m³/h

Head: up to 22 m

Temperature: -10 °C to +70 °C

Speed: 2950 rpm

Power: up to 3 kW

Standard material

Fully made of AISI304 SS.



Performance ranges

50Hz

MXO

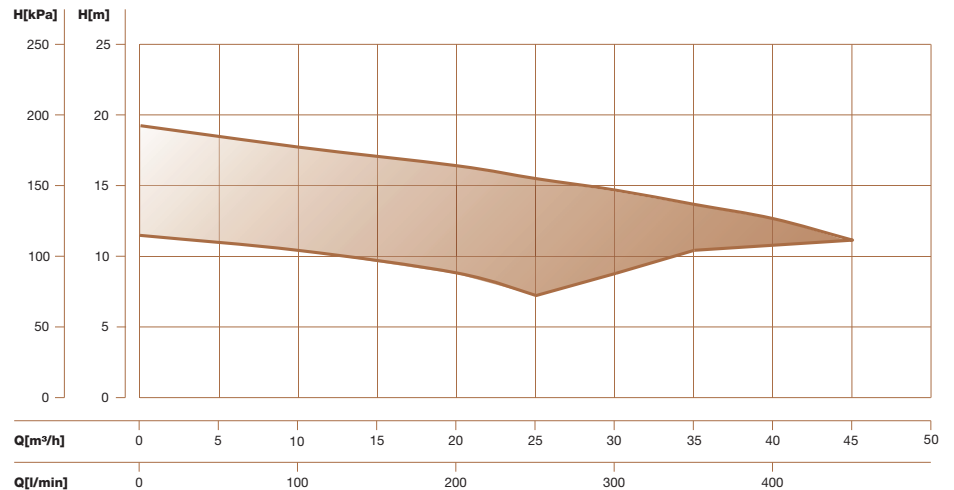

MXC

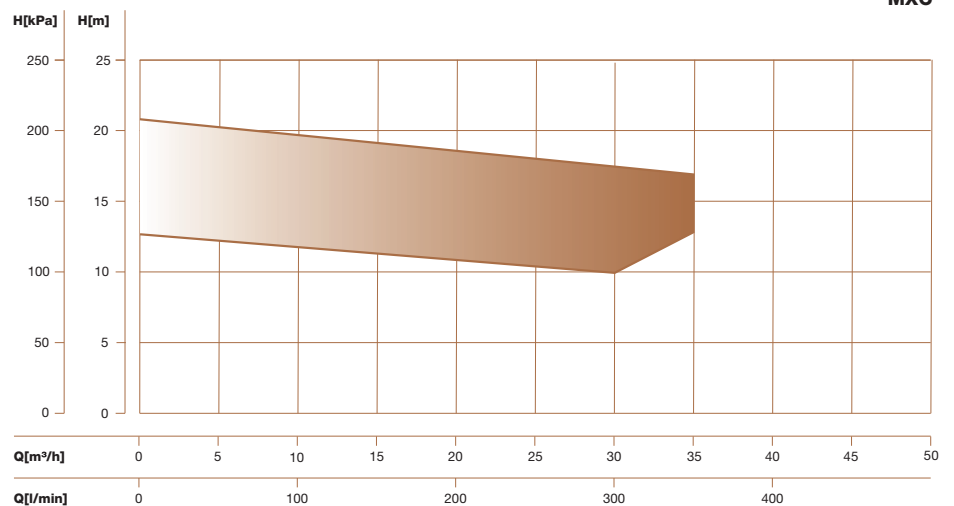

Applications

- Cooling systems
- Main HVAC applications
- Industrial washing machines
- Supply of water in buildings, farms or fountains

Definition of model

MX **O** **18** - **1,1** **T** **2340** **5** **2**

| Number of poles

| 5: 50 Hz
| 6: 60 Hz

| Rated voltage (x10) (V)

| T: Three phases
| S: Single phase

| Power P2 (kW)

| Rated flow (m³/h)

| O: Open impeller
| C: Close impeller

| Stainless steel pump

Structure features

MXO: Open impeller stainless steel horizontal single-stage centrifugal pump.

MXC: Close impeller stainless steel horizontal single-stage centrifugal pump. Axial suction and radial discharge.

Extended shaft configuration.

Inlet and outlet connections configurations.

Pump

MXO:

- Domestic water.
- Water supply for industrial washing machine.
- Water supply and drainage.
- Washing and surface cleaning for households.

MXC:

- Cooling, air condition and heating system.
- Cooling device.
- Washing device.
- Pressurization and transportation of water for domestic and industry

Operation conditions

- Liquid temperature: -10 °C to +70 °C.
- Ambient temperature: up to +40 °C.
- Altitude: up to 1000 m.
- Max. pressure of the system is 10 bar

Motor

- TEFC motor, 2-pole.
- Protection class: IP 55.
- Insulation class: F.
- Standard voltage:
1 x 230 V
3 x 400V / 3 x 230V
- Max. power of 1ph motor: 2.2 kW.

Installation requirements

- The pump shall be fastened on the base horizontally. When installing, please ensure the pump will not be forced by tension of the pipeline.
- The pump shall be installed on a ventilated and anti-freezing place.

Curves

The guidelines below apply to the curves shown on the next pages:

- All curves are based on the measured values of motor 3 x 400V, 50Hz: under the constant speed of 2900 rpm.
- Tolerances according to ISO9906, grade 3B.
- Measurement were made with airless water temperature of 20 °C
- The curves apply to a kinematic viscosity of $\mu=1\text{mm}^2/\text{sec}$ (1 cSt).

MXO

Section drawing

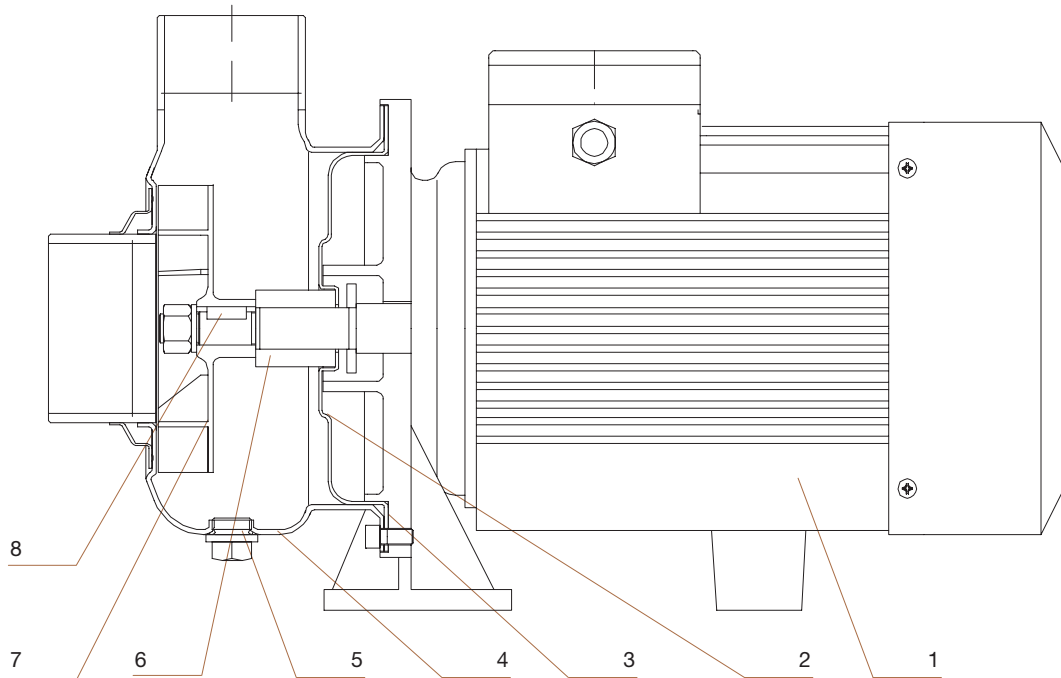

Material

N°	Parts	Material	AISI/ASTM
1	Motor		
2	Seal base plate	Stainless steel	AISI304
3	O ring	NBR	
4	Casing	Stainless steel	AISI304
5	Plug	Stainless steel	AISI304
6	Mechanical seal	Carbon / Silicon Fluoride	
7	Impeller	Stainless steel	AISI304
8	Key	Stainless steel	AISI304

MXC

Section drawing

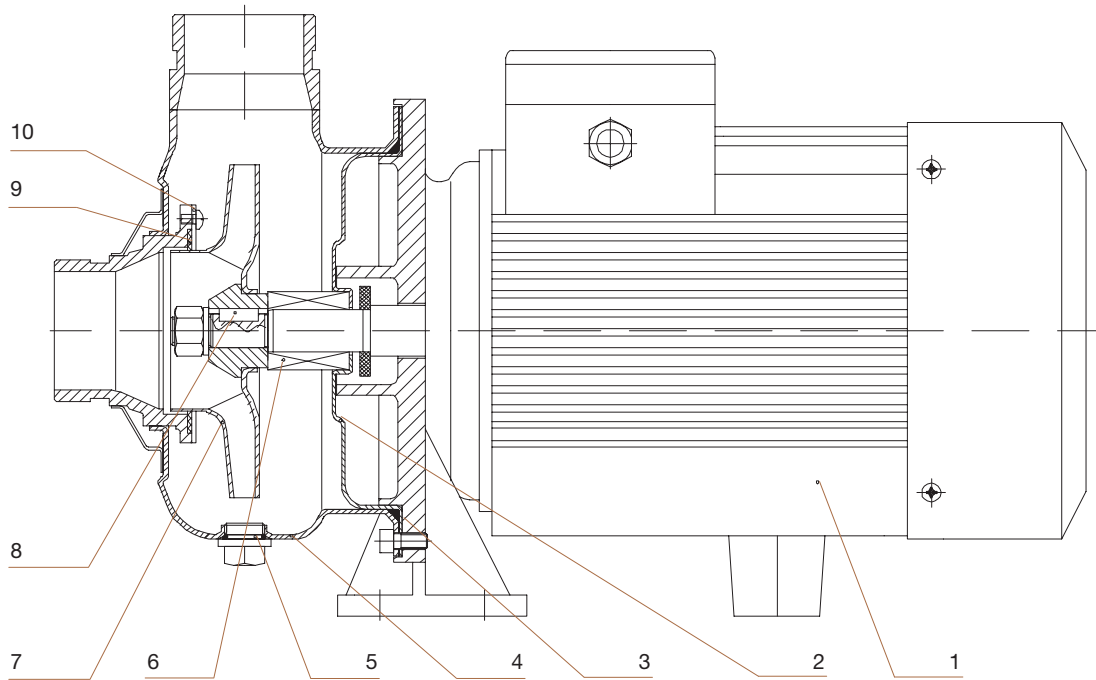

Material

N°	Parts	Material	AISI/ASTM
1	Motor		
2	Seal base plate	Stainless steel	AISI304
3	O ring	NBR	
4	Casing	Stainless steel	AISI304
5	Plug	Stainless steel	AISI304
6	Mechanical seal	Carbon / Silicon Fluoride	
7	Impeller	Stainless steel	AISI304
8	Key	Stainless steel	AISI304
9	Neck ring	F4	
10	Neck ring cover	Stainless steel	AISI304

MXO 50 Hz

Scope of performance

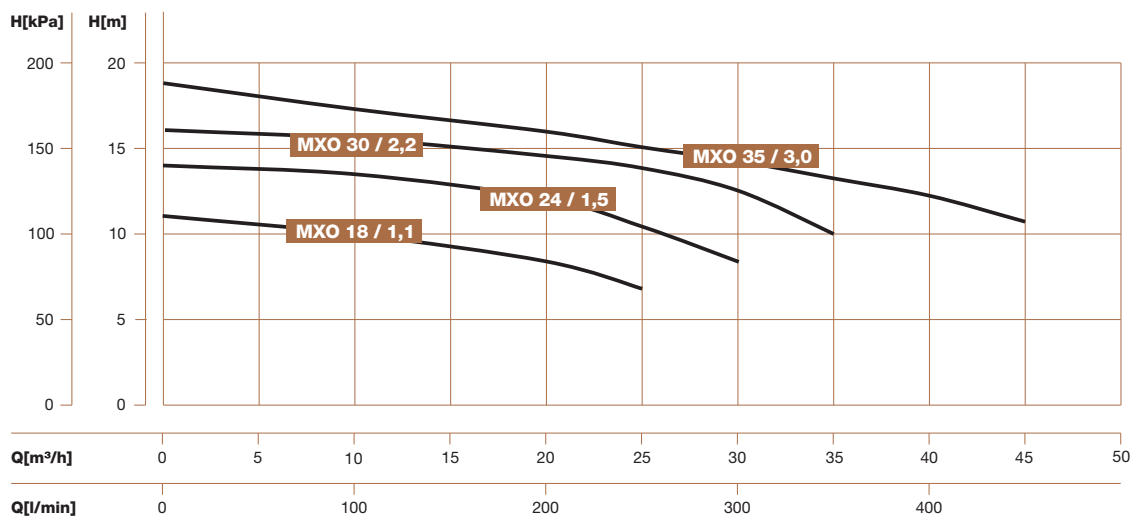

Performance

Modelo	I (A)		P2		Q m³/h	0	10	20	25	30	35	40	45
	1~230V	3~400V	kW	HP									
MXO 18/1.1	7	2,6	1,1	1,5	H (m)	11	10	9	7	—	—	—	—
MXO 24/1.5	9,2	3,5	1,5	2		14	14	12	11	9	—	—	—
MXO 30/2.2	14	4,9	2,2	3		16	16	15	14	13	10	—	—
MXO 35/3.0	-	6,3	3	4		19	17	16	15	14	13	12	11

MXC 50 Hz

Scope of performance

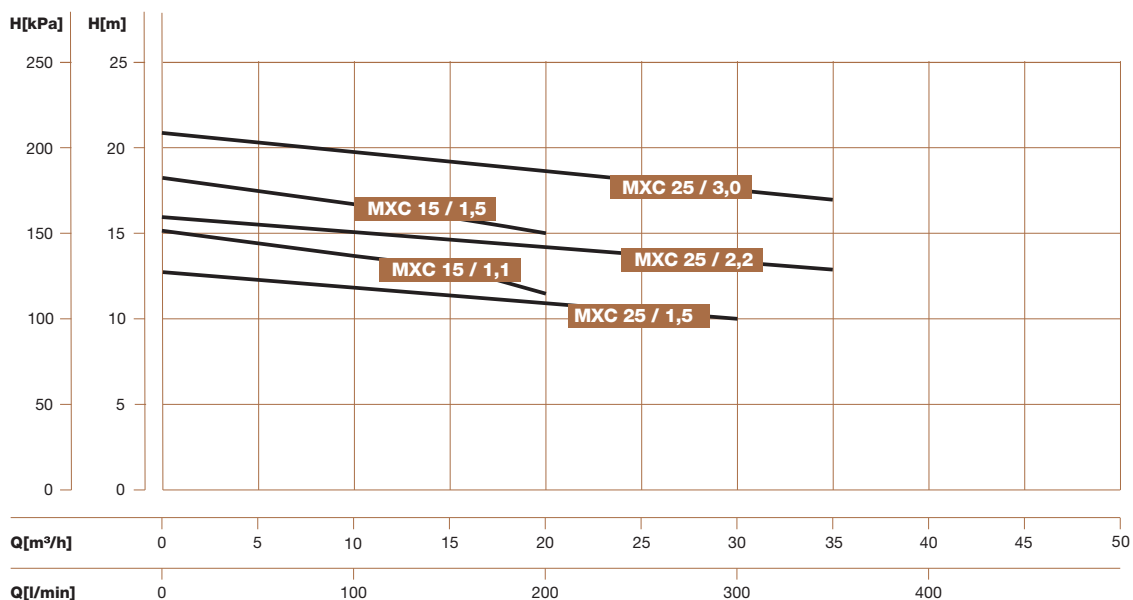

Performance

Modelo	I (A)		P2		Q m³/h	0	5	10	15	20	25	30	35
	1~230V	3~400V	kW	HP									
MXC15/1,1	7	2,6	1,1	1,5	H (m)	15	14	14	13	12	—	—	—
MXC15/1,5	9,2	3,5	1,5	2		18	17	17	16	15	—	—	—
MXC25/1,5	9,2	3,5	1,5	2		13	13	12	12	11	11	10	—
MXC25/2,2	14	4,9	2,2	3		16	16	15	15	14	14	13	13
MXC25/3,0	—	6,3	3	4		21	20	20	19	19	18	18	17

MXO 50 Hz

Weight and dimensions

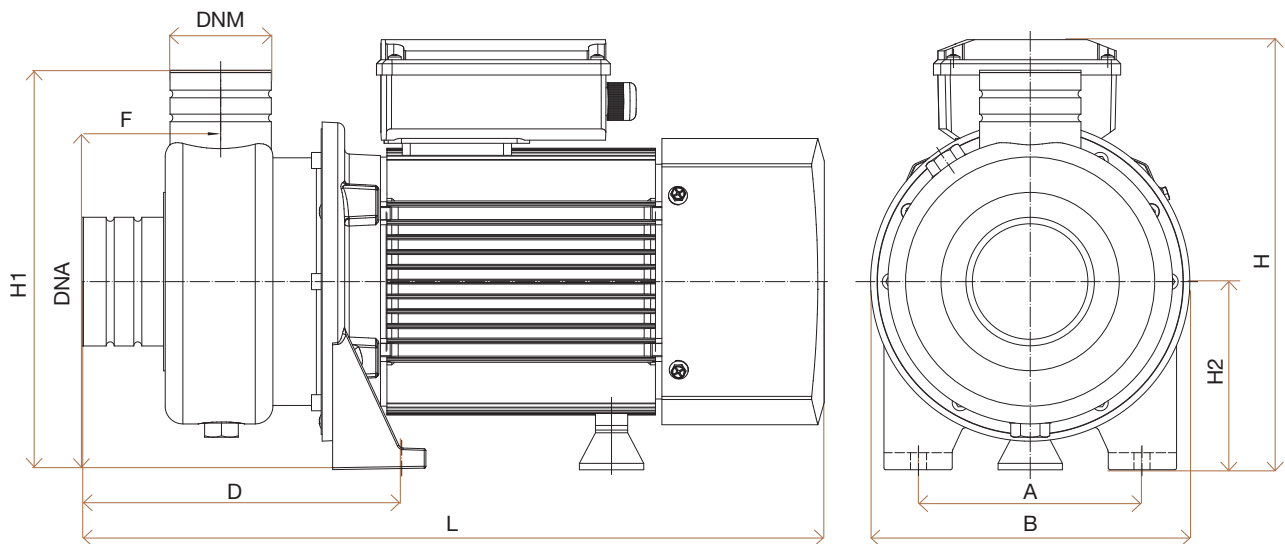

Model	A	B	D	E	F	L	H1	H2	H	DNA	DNM	Packaging	Weight
	mm											mm	kg
MXO 18/1.1	139	200	200	10	87	446	250	117	274	G2"	G2"	470 x 225 x 300	18
MXO 24/1.5	139	200	200	10	87	446	250	117	274	G2"	G2"	470 x 225 x 300	20
MXO 30/2.2	139	200	200	10	87	450	250	117	274	G2 1/2"	G2"	475 x 225 x 300	22
MXO 35/3.0	139	200	200	10	87	475	250	117	274	G2 1/2"	G2"	500 x 225 x 300	24

MXO 50 Hz

Weight and dimensions

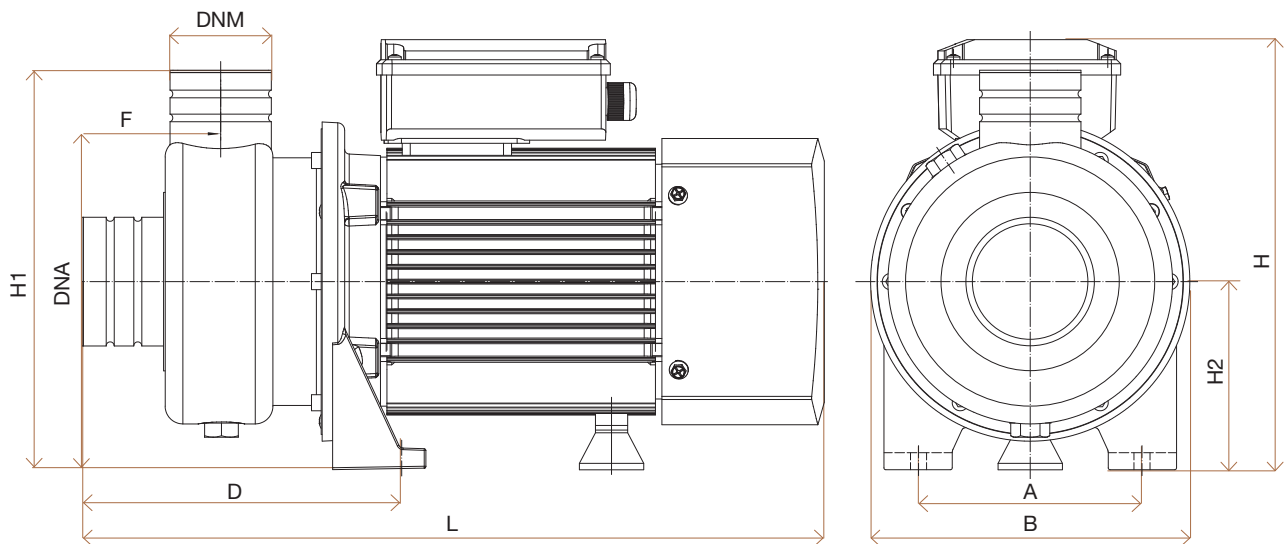

Model	A	B	D	E	F	L	H1	H2	H	DNA	DNM	Packaging	Weight
	mm												mm
MXO 18/1.1	139	200	200	10	87	446	250	117	274	G2"	G2"	470 x 225 x 300	18
MXO 24/1.5	139	200	200	10	87	446	250	117	274	G2"	G2"	470 x 225 x 300	20
MXO 30/2.2	139	200	200	10	87	450	250	117	274	G2 1/2"	G2"	475 x 225 x 300	22
MXO 35/3.0	139	200	200	10	87	475	250	117	274	G2 1/2"	G2"	500 x 225 x 300	24

BE
PUMPING
PARTNERS

www.alphadynamic.eu

AlphaDynamic Pumps SA

Production Plant - Greece
Inofita Industrial area
59th km Nat.Road Athens - Lamia
GR 320 11 Inofita Viotia, Greece

Tel +30 215 215 9520 , +30 215 215 9580
Email: Sales@alphadynamic.eu



We Make The Difference

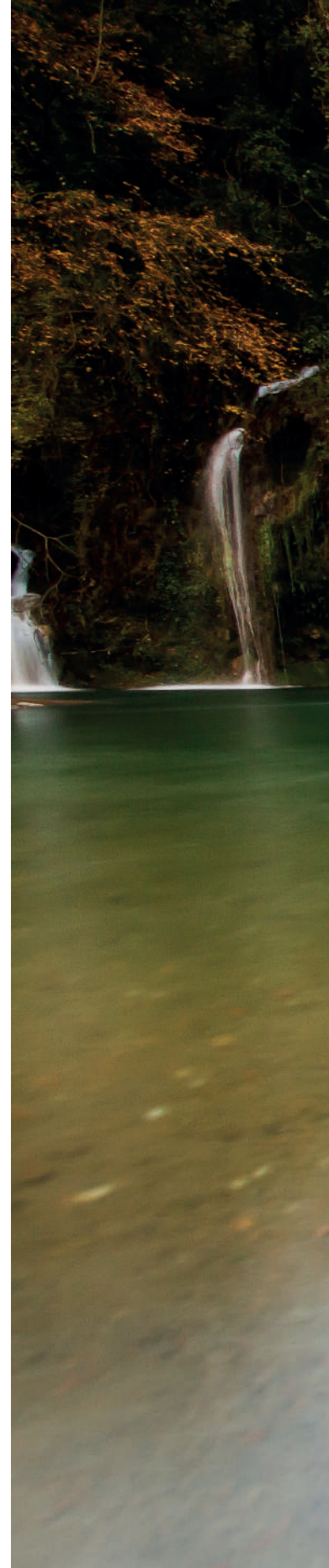

hydroo®